

SEEMU Series

LED Explosion Proof Emergency Light

SPECIFICATIONS

VOLTAGE AC100-277V

WATTAGE 10W / 11W / 12W

COLOR TEMP 3000K, 4000K, 5000K Kelvins

AMBIENT TEMP -40°C to +60°C (-40°F to +140°F)

HOUSING & HARDWARE • A360 die-casting aluminum
 • Stainless steel

LENS Glass with Metal Guards

LED LIFESPAN Up to 50,000 hours.

EMERGENCY TIME 3-hour emergency operation

PROTECTION IP66 / IK10 / IK08

DIMMING None Dimming

WARRANTY 5 Year Limited Warranty



DIMENSIONS

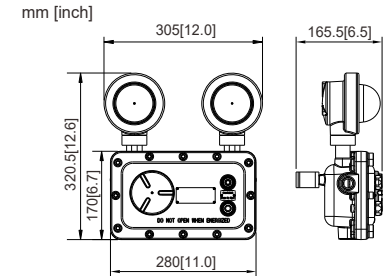

Quantity	Packing Size	Net Weight	Gross Weight
1 Pc	430 x 424 x 276 mm 16.93 x 16.69 x 10.87 Inch	8.0kg 17.64lb	9.5kg 20.94lb

KEY FEATURES

- **Energy Efficiency:** Features low wattage consumption for enhanced energy savings, making it environmentally friendly and cost-effective.
- **High Durability:** Constructed from A360 die-casting aluminum with stainless steel hardware, providing resistance to harsh conditions and a long lifespan of up to 50,000 hours.
- **Robust Certification:** Compliant with multiple safety standards, including Class I, II, III, UL 844 for hazardous locations, and IP66 for wet locations, ensuring reliability in diverse environments.
- **Emergency Functionality:** Equipped with a 3-hour emergency operation capability to maintain illumination during power outages.
- **Non-Serviceable LED Technology:** Features an integrated LED circuit board and driver that are not replaceable on site.

LUMENS

Wattage Input Voltage	Lumens	Emergency Time
10W AC100-277V	1000lm	3 Hours
11W AC100-277V	1100lm	3 Hours
12W AC100-277V	1200lm	3 Hours

RATINGS

- Class I, Division 1 Groups C, D
- Class I, Division 2 Groups A, B, C, D
- Class II, Division 1 Groups E, F, G
- Class II, Division 2 Groups F, G
- Class III
- UL 844 Hazardous Locations
- UL 1598A Marine Outside Type
- UL 1598 Wet Locations
- IP66 / Wet Locations
- Impact level: IK10 - Enclosure
- IK08 - Glass, with Metal Guards

ORDERING INFORMATION

ORDERING GUIDE

Series	Voltage	Wattage	CCT	Mounting
SEEMU	LV1 = 120-277 VAC	10 = 10W 11 = 11W 12 = 12W	S = 3000K I = 4000K C = 5000K	WM = Wall Mounted

WIRING DIAGRAM:

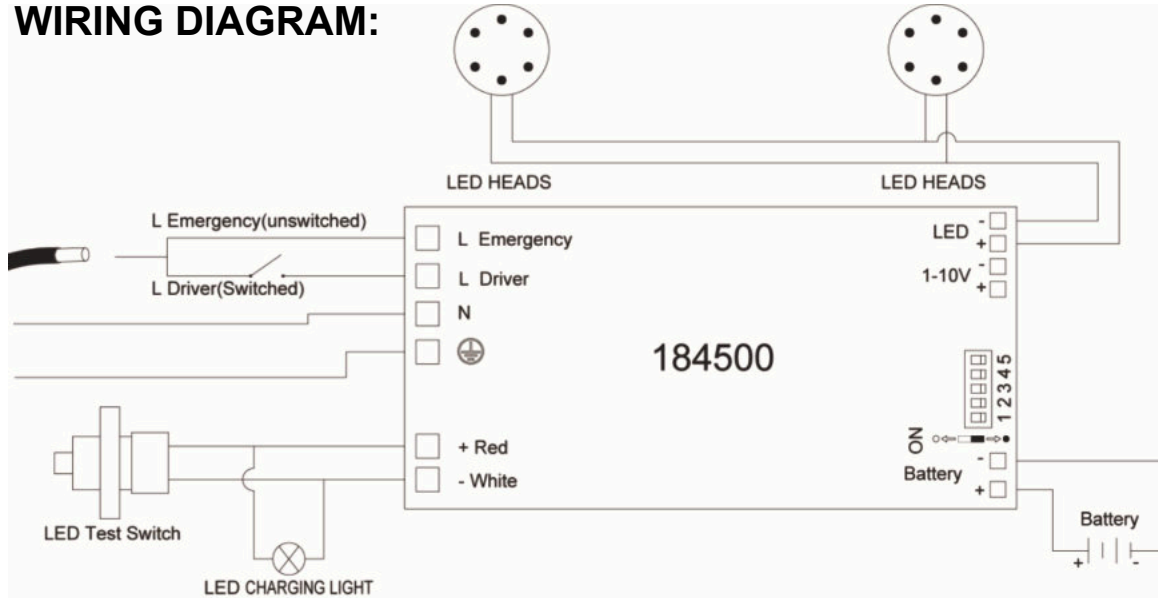

INSTALLATION: WALL MOUNTING

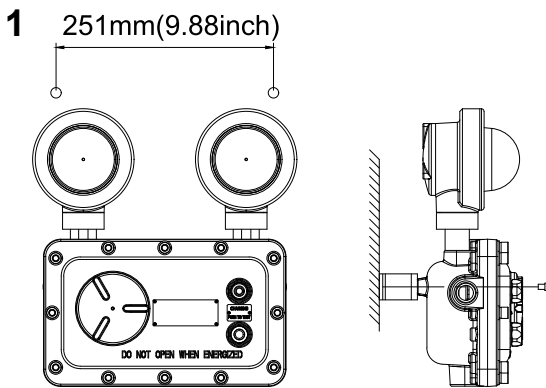

1. Drill two holes as fig. 1, the distance as per 251mm (9.88inch). Then install the the wall using 7/16" bolts (bolts are not lamp to provided).

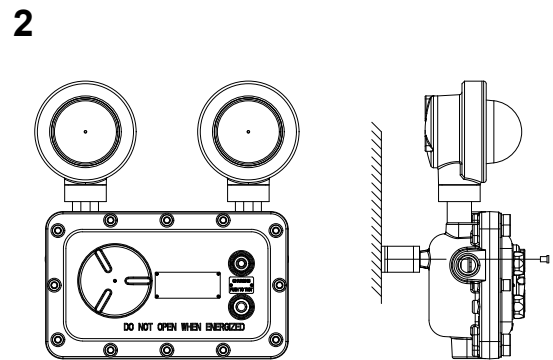

2. Select any one of the three 3/4 "NPT plugs as the interface for the cable input line.

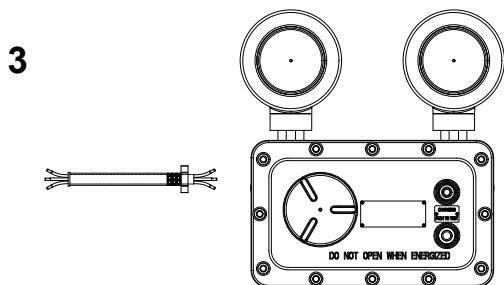

3. Remove the junction box cover (spiral cover) and insert the power cable into the junction box. Then connect the AC cable: black cable joins to L, white cable joins to N, green cable joins to grounding. Further, fill 16mm of chemical filler into the conduit and fix the conduit to the lamp body (it must be confirmed whether there are

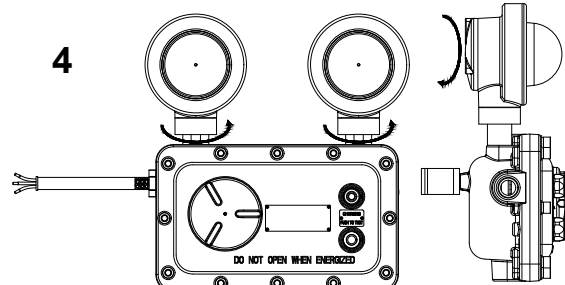

4. After installation, adjust the direction of the headlights as needed.